

See discussions, stats, and author profiles for this publication at: <https://www.researchgate.net/publication/325691163>

# Development of Brain-Controlled Assistive Feeding System

Article · January 2016

DOI: 10.21535/ijrm.v2i1.869

CITATIONS

0

READS

11

3 authors:



**Aida Khorshidtalab**

15 PUBLICATIONS 95 CITATIONS

[SEE PROFILE](#)



**Momoh Salami**

International Islamic University Malaysia

140 PUBLICATIONS 935 CITATIONS

[SEE PROFILE](#)



**Rini Akmelawati**

University of Adelaide

184 PUBLICATIONS 843 CITATIONS

[SEE PROFILE](#)

Some of the authors of this publication are also working on these related projects:



Decision Making in Cognitive Radio: Automatic Threshold Estimation [View project](#)



Slip modeling for mobile robot [View project](#)

# Development of Brain-Controlled Assistive Feeding System

Aida Khorshidtalab, M. J. E. Salami, and Rini Akmeliawati

Department of Mechatronics Engineering, International Islamic University Malaysia (IIUM), Kuala Lumpur, Malaysia

**Abstract**—Feeding difficulties and malnutrition are common phenomena in amyotrophic lateral sclerosis patients, locked in patients and people with upper limb disability. Feeding is often time consuming, unpleasant, and may result in choking or asphyxiation. Nowadays, robotic aids are applied to assist these people for eating. However, assistive robots that require movements from the user are not suitable for people with critical disabilities, including sensory losses, and/or difficulty in basic physical mobility. In this regard, a robotic system that can be controlled merely by brain signals is quite a remarkable aid. Therefore, based on the requirements for real-time assistive robot a prototype of an EEG-based feeding robot is proposed. The proposed feeding system enables the target group to eat independently. Experimental results show that the developed system is able to perform the required tasks, in real-time, with tolerable errors of around 17% in average. This amount of error can be further supervised to be reduced or in some cases even eliminated.

**Keywords**—Assistive feeding robot, electroencephalogram, brain-machine interface.

## I. INTRODUCTION

ASSISTIVE robots are one of the solutions by which disabled or elderly people can receive support to perform their daily activities such as eating. Various assistive robots have been developed to ease the eating process since late 1980s such as Handy1 [1], The Winsford feeder [2,3], Neater Eater, My Spoon [4], and Meal Buddy [2]. In some of them, a beverage straw is provided to assist the user to have liquid foods such as soup, or drinks [5]. There are also systems designed for multiple users such as [6]. The aforementioned robotic aids could enable only some handicapped to feed themselves without assistance since these assistive robots require the operator to control a joystick, some switches or buttons in the feeding process. Evidently, for amyotrophic lateral sclerosis patients and those with severe disabilities including sensory losses and difficulties in basic physical mobility, these robots are not practical. This research work is thus dedicated to develop and implement a simple and yet efficient brain-controlled feeding robot. The proposed feeding robot ease the process of feeding, increase the independency of severely disable people and improve the quality of their life.

It has been demonstrated in several experiments that brain

signals of animals and/or humans could be interfaced to activate and control mechanisms [7-18]. Brain Machine Interface (BMI) is a direct communication pathway between brain and an external electronic device, which aims to translate brain activities into control commands. This translation is through grouping different motor imagery signals and assigning a certain command to each group. Grouping signals can be done with the help of feature extraction and classifiers. Feature extraction highlights the properties of signal that make it distinct from the signals of the other mental tasks. Therefore, the performance of BMIs directly depends on the effectiveness of the applied feature extraction and classification algorithms. In this respect, the rest of paper is organized as follows. Section 2 describes the proposed system. This section is divided into two main subsections, 2.1 and 2.2 respectively. The first subsection consists of data acquisition, feature extraction, and classification, and the related experimental procedure. The second subsection consists of system design, mathematical model, communication and control strategy. Section 3 discusses the obtained results, and section 4 is the conclusion.

## II. PROPOSED SYSTEM DESCRIPTION

The general idea of a brain-controlled feeding robot is depicted in **Figure 1**. Assuming that user is ready to eat, there are several steps that need to be followed. In fact, two main steps should be carried out in order to link the user to the robot. The first is to extract the user's command from the user's brain activity and then to pass the command to the assistive robot. The second step is to get the feeding system/robot to execute the command. The flowchart of the proposed system explains the processing steps in details.

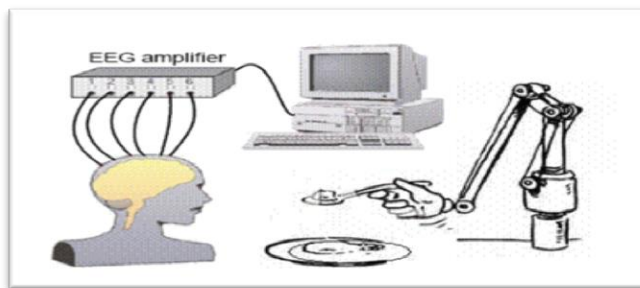
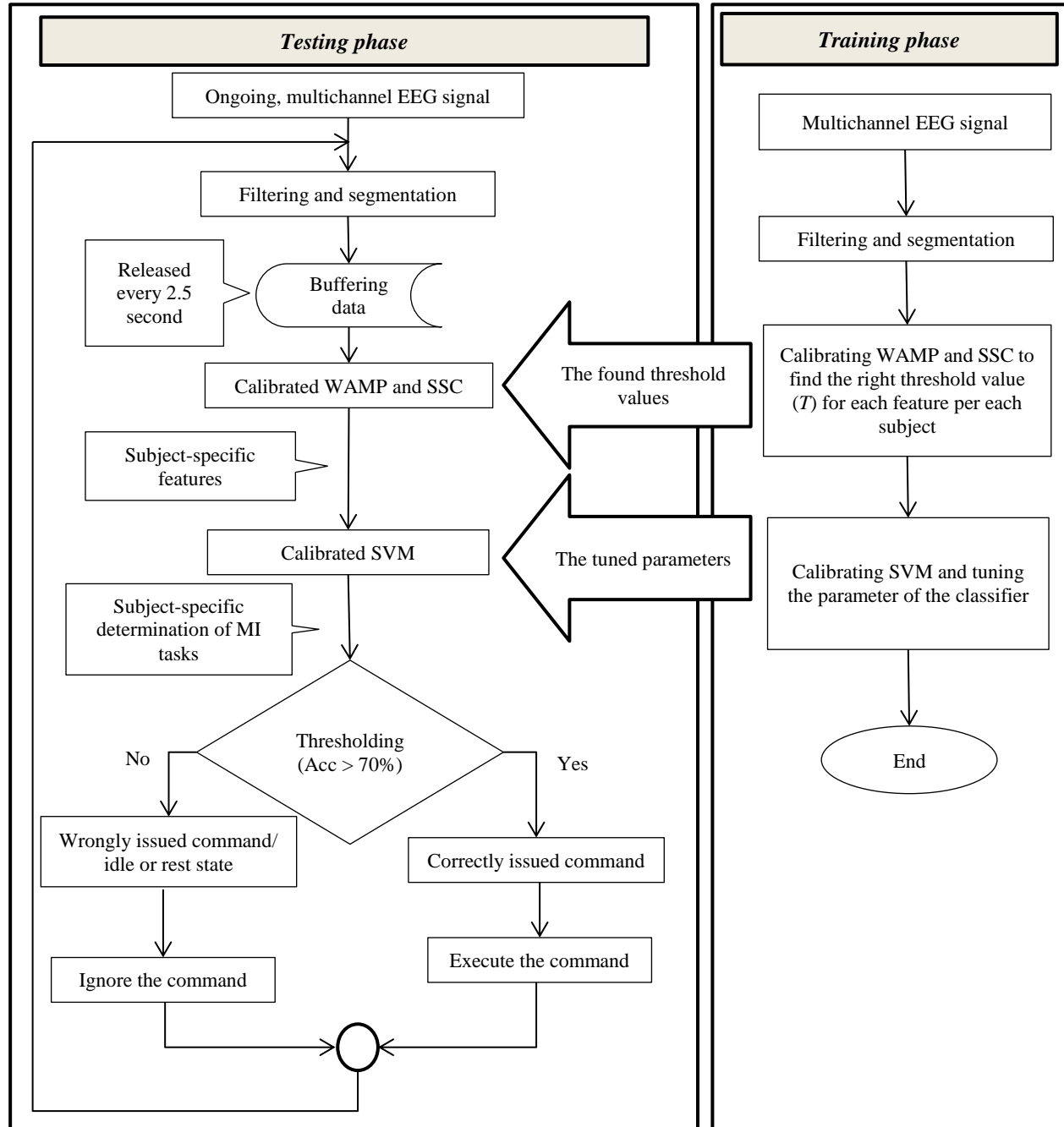

Figure 1 Brain-controlled feeding robot



### A. The First Step

The first step is further divided to several steps. After data acquisition and filtering the brain signals, data should be passed to the computer for processing. In this stage, the classifier will define which motor imagery task the user was thinking about based on the feature vector it receives. After the classifier decides which class the data belongs to the desired command will be assigned it to recognize the class of data. Thereafter, the command will be passed to the assistive robot for execution.

### 1) EEG signal acquisition

A set of movement-related potentials are recorded for this study. Instead of commonly used movement-related potentials, subjects were asked to think about the movements of their right hand, left hand, movement of their tongue to the right side of their mouth and to their left side of their mouth.

EEG signals were recorded from multiple electrodes placed on the subject's scalp, resulting in multichannel time series data. Three electrodes known as C3, Cz, and C4 were located on the subject's scalp based on the International 10-20

electrode placement system [19], in mono-polar montage. These three electrodes cover the sensory motor cortex and their locations have been recommended for recording motor imagery movements [20, 21]. Reference electrode was located on the left mastoid, behind the ear and the ground electrode was placed at Fpz near forehead.

The training experiment consists of three runs for each of the four movements. The EEG data is from two selected subjects among the fifteen subjects in [22]. For recording signal, subjects were asked to replace the desired movement with imagination of the related movements.

EEG signals were recorded with g.tec device at the rate of 512Hz sampling frequency. Subjects were free of medication and central nervous system abnormalities and had no prior experience with EEG-based systems.

## 2) Feature extraction techniques

Measuring brain activities through EEG signals leads to acquisition of a large amount of data. Feature extraction highlights important data and eliminates redundant or not informative one. This transformation causes dimensionality reduction, which speeds up the classification process [23]. Time-domain features are determined based on signal's amplitude and they require no complex calculation. Therefore, they are the suitable choices for real time applications. Among several statistical time-domain features, two of them are selected for this work. These two features are among the most successful time-domain features for EEG data addressed in [22].

### a) Slope Sign Changes (SSC)

Slope Sign Changes is a feature that represents a frequency aspect of the EEG signal with the number of times that the slope of waveform changes its sign, as represented in Equation 1. In SSC, a threshold is included to reduce the noise [22].

$$\{x_i > x_{i-1} \text{ and } x_i > x_{i+1}\} \text{ or } \{x_i < x_{i-1} \text{ and } x_i < x_{i+1}\} \quad \text{and} \quad (1)$$

$$f(x) = \begin{cases} 1 & |x_i - x_{i+1}| \geq T \text{ or } |x_i - x_{i-1}| \geq T \\ 0 & \text{otherwise} \end{cases}$$

$$SSC_K = \sum_{i=2}^{N-1} f(x)$$

### b) Willison Amplitude

Willison Amplitude, as presented in Equation 2, counts the number of times that the absolute value of difference between EEG signal amplitude of two consecutive samples exceeds a predetermined threshold value [22].

$$WAMP_K = \sum_{i=1}^{N-1} f(x) \quad (2)$$

$$f(x) = \begin{cases} 1 & |x_i - x_{i+1}| > T \\ 0 & \text{otherwise} \end{cases}$$

In these equations,  $N$  is the length of segment,  $k$  is the current segment,  $x_i$  is the current point of signal,  $i$  is the index of current point and  $T$  is the threshold value. The threshold values for these two features are obtained by the introduced method in [22] for each subject.

## 3) Classification

Support Vector Machine (SVM) is one of the best state-of-the-art classifiers with lower complexity compared to other classifiers such as neural network and fuzzy classifiers. The main idea behind SVM is to find discriminant hyperplanes that separate the data that belongs to different classes with the maximum possible margin. Maximizing the margins increases the generalization capabilities of the classifier. SVM uses a regularization parameter that enables accommodation to outliers and tolerates errors on the training set. SVM has several advantages due to its margin maximization and regularization term. Insensitivity to overtraining and dimensionality, a few parameters that need to be tuned manually and good generalization properties are the other advantages of SVM [24].

## 4) Experiment procedure

The experiment was done based on two hundred fifty six samples as a segment. In accordance with the specified segmentation and the sampling frequency, in each half a second two feature values from each channel, C3, Cz, C4, were extracted, which provided six feature values per each half a second.

For each command to be issued with an acceptable confidence level, enough data should be provided for the classifiers. In each five seconds, twenty feature values are extracted from one channel of the recorded data. By having three channels, in each five seconds, sixty feature values are extracted. These features are buffered, combined to a matrix, and passed to an already calibrated classifier with the training data. As the proposed system is a subject-specific system it must be carefully calibrated and adapted to the user before implementation. It should be noted that, before operating a BMI system some sessions of calibration/training is necessary. The calibration task, which is generally done offline, includes the tuning of the classification algorithm's parameters and the selection of the optimum features.

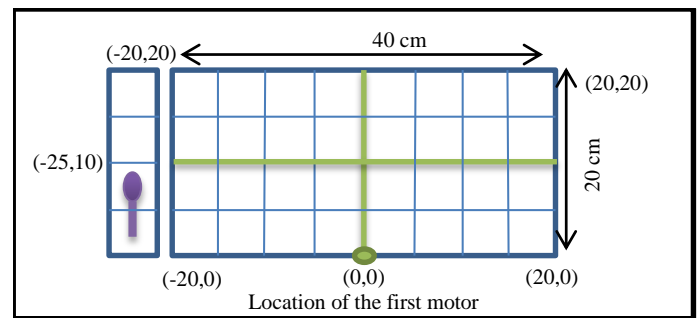

Figure 2 The two trays and their related coordination for the system

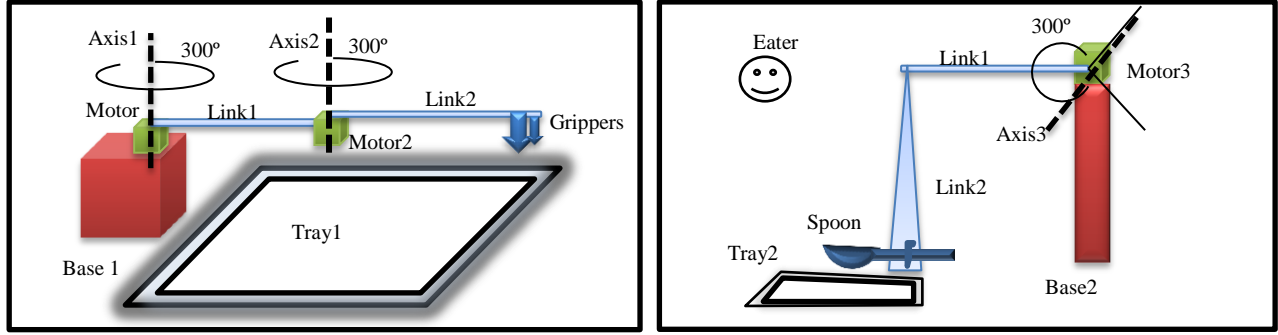

Figure 3 Configuration of (a) the gripper-arm or the robot (b) the spoon-arm or the mechanism

### B. The Second Step

The second step consists of the system design, mathematical model, control strategy, and command execution. The proposed robotic system which is inspired by [25] is depicted in **Figure 3**. It consists of one robot and one mechanism. The robot also known as the gripper arm, collects food from the tray and places it into the spoon, while the mechanism moves the spoon to the eater's mouth. Both, the robot and the mechanism, receive commands independently from the user.

As depicted in **Figure 2**, two trays are being considered for the system. The first tray, which is the main tray, is supposed to contain food and the second tray is located under the spoon.

Tray one is 200 by 400 mm in rectangle shape and tray two is 50 by 200 mm. Both trays are divided to small imaginary parts of 50 by 50 mm in a matrix form as shown in **Figure 3**. To have access to each and every points of these two trays with the end effector of the gripper-arm, the need of knowing the joint angles by the controller arises. In other words, finding the joint variables in terms of position variables is necessary to reach desired points on the trays. Inverse Kinematics Solution helps to define the coordination that food needs to be picked up from and the coordination that food needs to be put in it. Therefore, each part is known by its coordination.

#### 1) Mathematical model

For the gripper arm, the robot, the joints are typical revolute joints that rotate along parallel axes. The end point of a manipulator is moved to the desired positions by driving the joints through appropriate angles.

##### a) Inverse Kinematics Solution of a Two-Link Manipulator

The forward kinematic equations in terms of joint variables and end effector position, according to **Figure 4** are,

$$x = l_1 \cos \theta_1 + l_2 \cos (\theta_1 + \theta_2) \quad (3)$$

$$y = l_1 \sin \theta_1 + l_2 \sin (\theta_1 + \theta_2) \quad (4)$$

By expanding Equation 3 and 4 there would be,

$$x = l_1 \cos \theta_1 + l_2 \cos \theta_1 \cos \theta_2 - l_2 \sin \theta_1 \sin \theta_2 \quad (5)$$

$$y = l_1 \sin \theta_1 + l_2 \sin \theta_1 \cos \theta_2 + l_2 \cos \theta_1 \sin \theta_2 \quad (6)$$

Let assume,  $k_1 = l_1 + l_2 \cos \theta_2$  and  $k_2 = l_2 \sin \theta_2$

Simultaneous solution of Equations 5 and 6 give,

$$\sin \theta_1 = \frac{k_1 y - k_2 x}{k_1^2 + k_2^2} \quad (7)$$

$$\cos \theta_1 = \frac{k_1 x + k_2 y}{k_1^2 + k_2^2} \quad (8)$$

Thus the joint variables  $\theta_1$  and  $\theta_2$  are obtained from the following two equations:

$$\theta_1 = \text{atan2}(\sin \theta_1, \cos \theta_1) \quad (9)$$

$$\theta_2 = \text{atan2}(\sin \theta_2, \cos \theta_2) \quad (10)$$

where  $\text{atan2}(x, y)$  is defined as  $2 \arctan \frac{\sqrt{x^2 + y^2} - x}{y}$ .  $\theta_1$  and  $\theta_2$  for five major desired coordination, based on Equations 9 and Equation 10, are calculated. These five coordinates as shown in **Figure 5**, are the four ending points of the first tray in addition to the location of the spoon. The whole coverage area of the first arm is demonstrated in **Figure 6**.

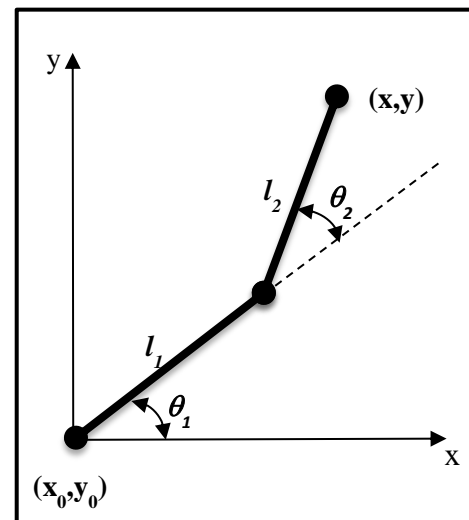

Figure 4 Definition of the gripper arm's parameters

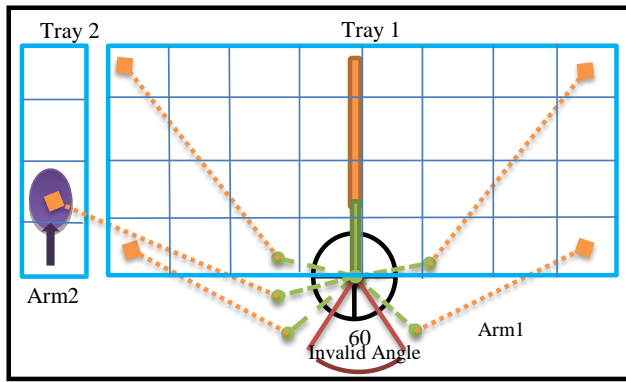

Figure 5 Illustration of gripper arm's accessibility to the trays

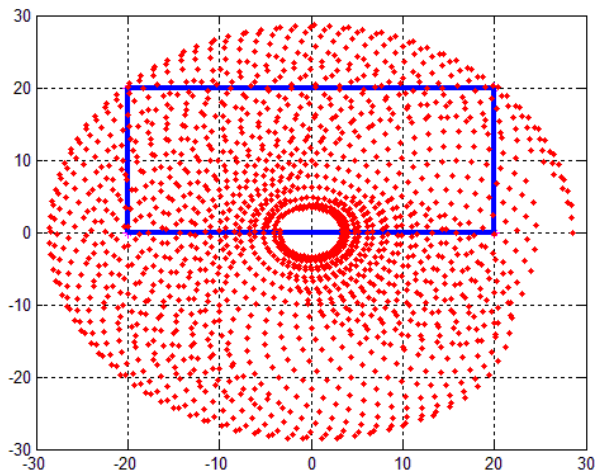

Figure 6 The coverage area of the gripper arm based on the assumed coordination

## 2) Communication and Control

The selected actuators for the robot and the mechanism are Dynamixel® robot actuator. The two motors are controlled with Matlab software. Signal processing including segmentation, feature extraction, and classification are done with Matlab too. The developed system communicated with the user through a screen (could be computer's monitor) and showed available choices to the user via dialogue boxes, generated with Matlab GUI, as shown in **Figure 7**. User could select any of the offered choices with one of the predefined imagery movement assigned to it. A short guide is provided in each dialogue box to let the user know about the imagery movement assigned to each option.

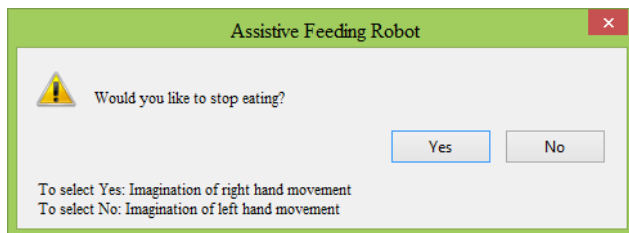

Figure 7 Brain-controlled feeding robot

There is no limitation in assigning a certain command to a certain imagery movement. However, to reduce the occurrences of errors and having a smoother functionality, imagery movements which are more discriminable are assigned to more complicated, more important and/or more frequent commands. For instance, left hand and right hand imagery movement are more discriminable compared to imagery tongue movements, either to right or left side of mouth. Consequently, imagery hand movements are assigned to the commands which are more important and/or choices which is more likely to be selected. For high level commands, which consist of a chain of sequential actions, the same assigning policy is applied. For example when the user wants to stop eating and the "Stop" command is issued, the spoon arm and the gripper arm both need go back to their initial positions. This one command makes the system to perform a chain of sequential actions.

## III. RESULTS

The online evaluation of the system was based on the ability of two selected subjects in [22] to control the feeding system. One of the selected subjects was the one with the highest accuracy among others in the offline evaluation and the other one had just an average satisfactory result. Both subjects could perform satisfactory with the feeding system after some sessions of training. The more the subjects got familiar with the system and the more they felt comfortable with it the better accuracy they could obtain.

A threshold value of 70% accuracy is applied for the system to separate wrongly issued command from the acceptable commands. This threshold value is assumed to be the required threshold value for BCI applications related to communication [26]. By ignoring wrongly issued commands, for the first subject 85% accuracy and for the second one 78% accuracy were achieved. The calculated accuracy is based on the number of occurrence of error among forty trials of issuing different commands. The issued commands are among the four considered motor imagery movements in this work. The obtained accuracy for the commands in each 5 seconds is in agreement with the requirements in [27].

## IV. CONCLUSION

In this study, a real-time brain-controlled feeding robot was proposed. A prototype of the system was developed which was controllable with brain's signals in real-time. The system could perform with  $83 \pm 5\%$  accuracy. One decision making per each five seconds is a reasonable speed for those who would like to take their time while eating.

There are several arguments associated with the general idea of assistive feeding robots due to the condition of the potential users. The common problem among incapable people is the feeding interval. In some cases, each feeding interval is quite short but the user needs time to chew and swallow the food. Sometimes, they prefer to take a short rest after taking a few spoons of food due to their inability or tiredness. Assistive feeding robots are favorable because of the following reasons. Firstly, the users can chew their food sufficiently when they do



not need to consider that their caregiver is having the next spoon ready for serving. Besides, they can eat their desired food when they want to eat. The feeding robots allow the users to enjoy their meal independently at any time of the day and as many times as they want.

Future work can be the combination or integration of different types of bio-signals which provide additional possibilities for communication and control. In case of using such methods, the occurrence of the main signal being affected by the other signals should be considered. Additionally, improving the proposed system in a way that provides a more convenient and faster eating is recommended.

#### REFERENCES

- [1] Topping, M. J., & Smith, J. K. (1999). The Development of HANDY 1, a Robotic System to assist the severely disabled. *International Conference on Rehabilitation Robotics*.
- [2] Sammons Preston. *Patterson Medical*. [VIEW](#)
- [3] Hermann, R. P., Phalangas, A. C., Mahoney, R. M., Alexander, M. A. (1999). Powered Feeding Devices: An Evaluation of Three Models. *Arch Physics Medical Rehabilitation*, 80, 1237-1242. [CrossRef](#)
- [4] Soyama, R., Ishii, S., & Fukase, A. (2003). The Development of Meal assistance Robot MySpoon. *International Conference on Rehabilitation Robotics*, 88-91.
- [5] Pourmohammadali, H., Kofman, J., & Khajepour A. (2007). Design of a multiple-user intelligent feeding robot for elderly and disabled people. *30th Canadian Medical and Biological Engineering Conference (CMBEC30)*.
- [6] Guglielmelli, E., Lauro, G., Chiarugi, F., Giachetti, G., Perrella, Y., Pisetta, A., & Scoglio, A. (2009). Self-feeding Apparatus, US Patent 2009/0104004.
- [7] Chapin, J. K., Moxon, K. A., Markowitz, R. S., & Nicolelis, M. A. L. (1999). Real-time control of a robot arm using simultaneously recorded neurons in the motor cortex. *Nat.Neurosci*, 2, 664-670. [CrossRef](#)
- [8] Kennedy, P. R., Bakay, R. A. E., Moore, M. M., Adams, K., & Goldwithe, J. (2000). Direct control of a computer from the human central nervous system. *IEEE Transactions on Biomedical Engineering*, 8, 198-202. [CrossRef](#)
- [9] Mason, S. G., & Birch, G. E. (2000). A brain-controlled switch for asynchronous control applications. *IEEE Transactions on Biomedical Engineering*, 47, 1297-1307. [CrossRef](#)
- [10] Taylor, D. M., Tillery, S. I. H., & Schwartz, A. B. (2002). Direct cortical control of 3D neuroprosthetic devices. *Science*, 296, 1829- 1832. [CrossRef](#)
- [11] Black, M. J., Bienenstock, E., Donoghue, J. P., Serruya, M., Wu, W., & Gao, Y. (2003). Connecting brains with machines: the neural control of 2D cursor movement. *Proceeding of the 1<sup>st</sup> International IEEE EMBS Conference Neural Engineering*. [CrossRef](#)
- [12] Gao, X., Xu, D., Cheng, M., & Gao, S. (2003). A BCI-Based environmental controller for the motion-disabled. *IEEE Transactions on Neural Systems and Rehabilitation Engineering*, 11(2), 137-140. [CrossRef](#)
- [13] Mussa-Ivaldi, F. A., & Miller, L. E. (2003). Brain-machine interfaces: computational demands and clinical needs meet basic neuroscience. *Trends Neurosci*, 26, 329-33. [CrossRef](#)
- [14] Bayliss, J. D. (2003). Use of the evoked P3 component for control in a virtual apartment. *IEEE Transactions on Neural Systems and Rehabilitation Engineering*, 11(2), 113-116. [CrossRef](#)
- [15] Rebsamen, B., Burdet, E., Guan, C., Zhang, H., Teo, C. L., Zeng, Q., Ang, M., & Laugier, C. (2006). A brain-controlled wheelchair based on P300 and path guidance. *Proceedings of IEEE/RAS-EMBS International Conference on Biomedical Robotics and Biomechatronics*. [CrossRef](#)
- [16] Galan, F., Nuttin, M., Lew, E., Ferrez, P. W., Vanacker, G., Philips, J., Millan, J. del R. (2008). A brain-actuated wheelchair: asynchronous and non-invasive Brain-computer interfaces for continuous control of robots. *Clin Neurophysiol*, 119(9):2159-69. [CrossRef](#)
- [17] Ang, K. K., Guan, C., Chua, K. S. G., Ang, B. T., Kuah, C. W. K., Wang, C., Phua, K. S., Chin, Z. Y., and Zhang, H. (2009). A clinical study of motor imagery-based brain computer interface for upper limb robotic rehabilitation, in Proc. EMBC, pp. 5981-5984.
- [18] Bin, G., Gao, X., Yan, Z., Hong, B., & Gao, S. (2009). An online multi-channel SSVEP-based brain-computer interface using a canonical correlation analysis method. *Journal of Neural Engineering*. [CrossRef](#)
- [19] Jasper H.H. (1958). The ten twenty electrode system of the International Federation. *Electroencephalography and clinical neurophysiology*, 10:371-375.
- [20] Müller-Gerking, J., Pfurtscheller, G., & Flyvbjerg, H. (1999). Designing optimal spatial filters for single-trial EEG classification in a movement task. *Clinical neurophysiology*, 110(5), 787-798. [CrossRef](#)
- [21] Homan, R. W., Herman, J., & Purdy, P. (1987). Cerebral location of international 10-20 system electrode placement. *Electroencephalography and clinical neurophysiology*, 66(4), 376-382. [CrossRef](#)
- [22] Khorshidtalab, A., Salami, M. J. E., & Hamed, M. (2013). Robust classification of motor imagery EEG signals using statistical time-domain features. *Physiological measurement*, 34(11), 1563. [CrossRef](#)
- [23] Herman, P., Prasad, G., McGinnity, T. M., & Coyle, D. (2008). Comparative analysis of spectral approaches to feature extraction for EEG-based motor imagery classification. *Neural Systems and Rehabilitation Engineering, IEEE Transactions on*, 16(4), 317-326. [CrossRef](#)
- [24] Burges, C. J. C. (1998). *A tutorial on support vector machines for pattern recognition*. Knowledge Discovery and Data Mining. [CrossRef](#)
- [25] Song, W. K., Kim, J., An, K. O., Lee, I. H., Song, W. J., & Lee, B. S. (2010). New Dual-Arm Assistive Robot for Self-Feeding. In *Second International Symposium on Quality of Life Technology, Las Vegas, USA*.
- [26] Kübler, A., Neumann, N., Wilhelm, B., Hinterberger, T., & Birbaumer, N. (2004). Predictability of brain-computer communication. *Journal of Psychophysiology*, 18(2/3), 121-129. [CrossRef](#)
- [27] Huggins, J. E., Wren, P. A., & Gruis, K. L. (2011). What would brain-computer interface users want? Opinions and priorities of potential users with amyotrophic lateral sclerosis. *Amyotrophic Lateral Sclerosis*, 12(5), 318-324. [CrossRef](#)

APPENDIX

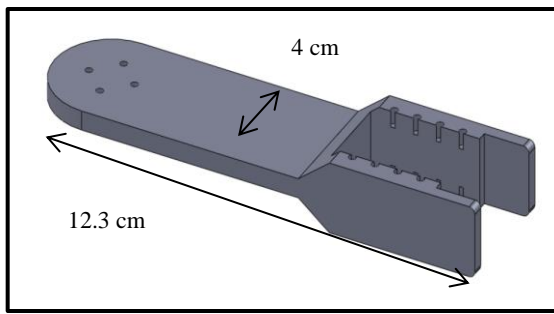

(a)

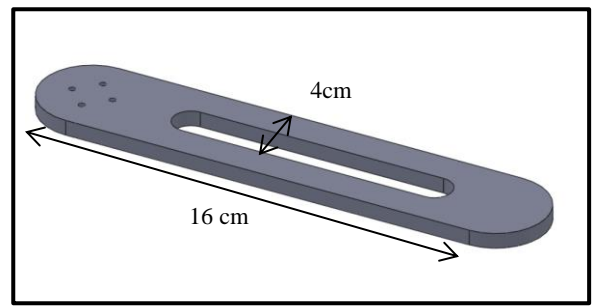

(b)

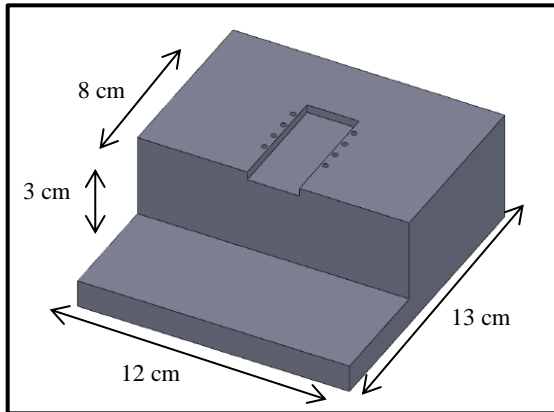

(c)



(d)

Figure 1 Parts of the robot (a) link one (b) link two (c) base (d) gripper

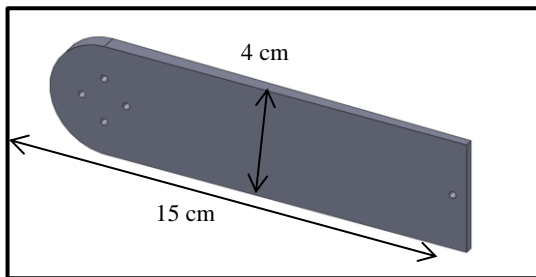

(a)

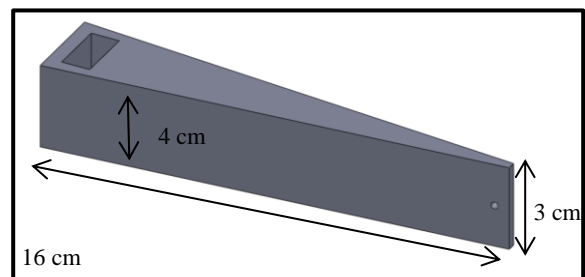

(b)

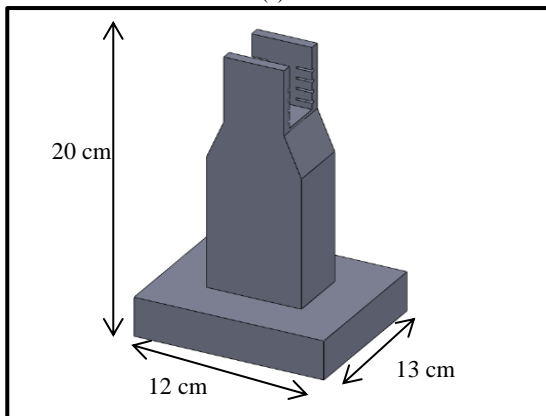

(c)

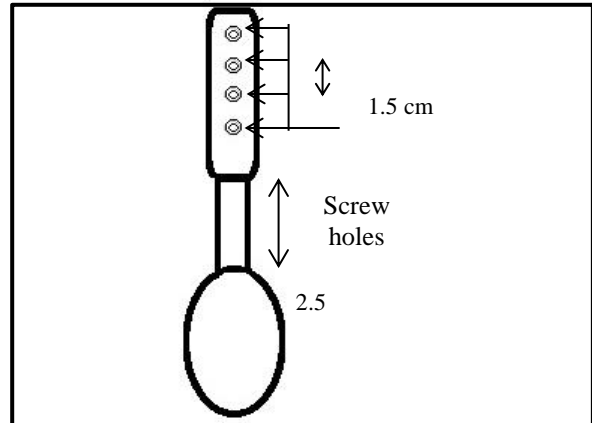

(d)

Figure 2 Parts of the mechanism (a) link one (b) link two (c) base (d) spoon



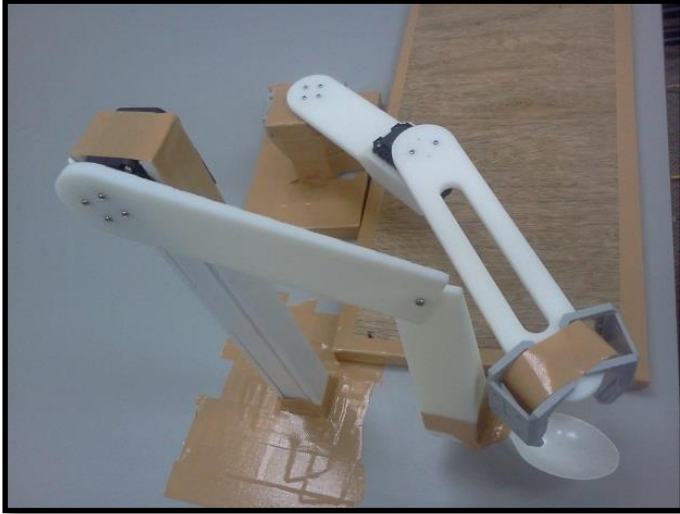

**Figure 3 Assembled arm-robot and mechanism**

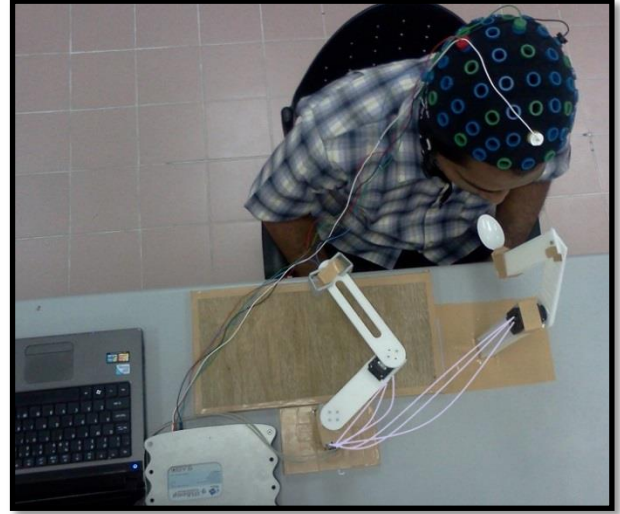

**Figure 4 The developed system while feeding**